

Humidifier Product Catalogue



neptronic[®]

Overview

Since 1976, Neptronic has been committed to advancing our products by utilizing all that technology has to offer. Our commitment to quality is the foundation of every stage in our process. We build from the ground up, beginning with a thorough exploration of the most current ideas, and deliver a product that's engineered to perform. Neptronic's focus on integration across the board means that we can deliver a system suited to your exact needs.

The importance of humidification in our daily lives cannot be understated. Humidification is an essential component in maintaining ideal climate

conditions for a variety of applications: the production of sensitive electronics that require environments completely free of dust and particulates; careful control of sterile conditions in a hospital's surgical suites; preservation of priceless manuscripts and artworks in museums, or your personal comfort at home and in the office. Neptronic's complete humidifier series with integrated controllers equipped with BACnet or Modbus will fulfill whatever your situation requires.

Demand the best. We do.

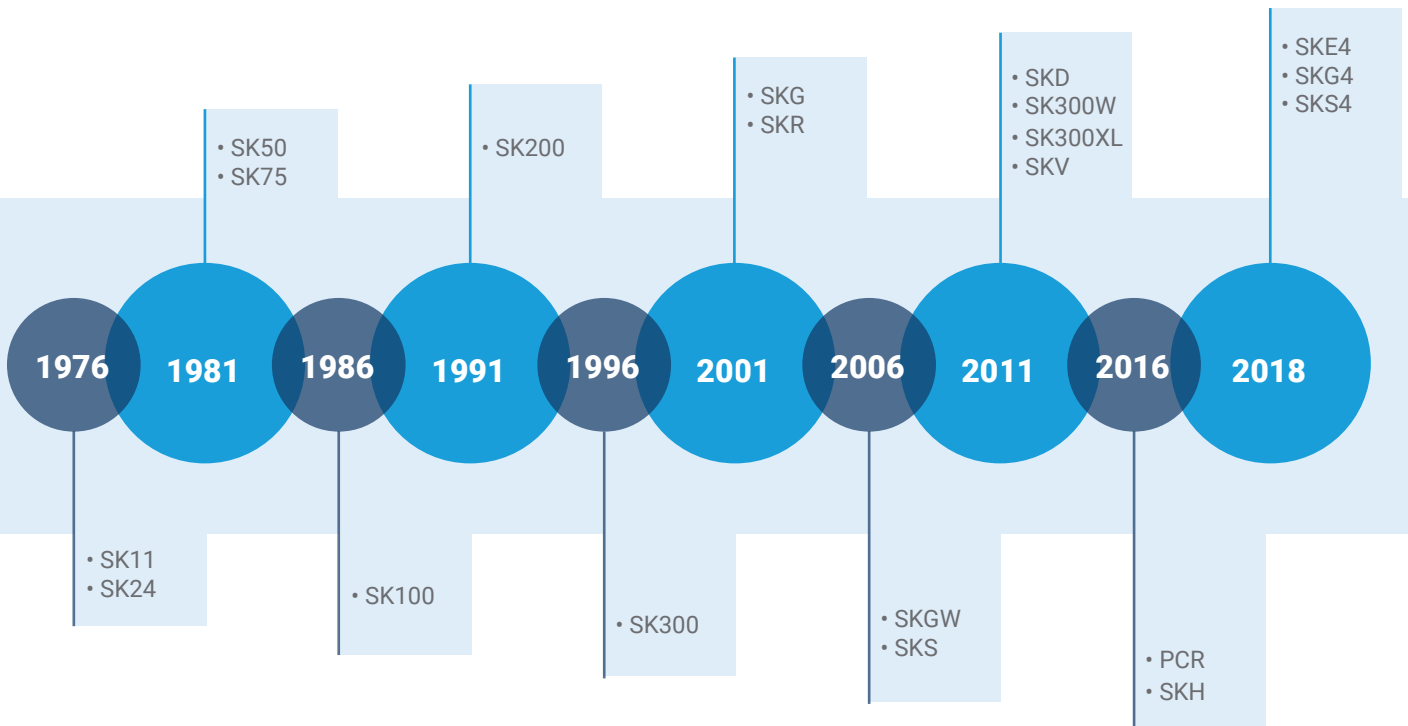

Humidifier Product Line

SKE4 ⚡



Electric

- Capacities from 6 - 300 lb/hr
- Remove chamber easily, without tools
- Outdoor unit available

SKG4 🔥



Gas Fired

- Capacities from 110 - 810 lb/hr
- Modular design
- Outdoor unit available

SKS4 ↑↑↑



Steam to Steam

- Capacities from 17 - 1250 lb/hr
- Scale management system for easy maintenance
- Insulated external panels

SKR ⚡



Residential

- Capacities from 4.5 - 12 lb/hr
- Permanent cleanable chamber
- Reliable siphon drain

SKH 🌪️



High Pressure Atomizer

- Capacities up to 4638 lb/hr
- Up to 3 zones
- Installation in-duct or in-space

SKV →→→

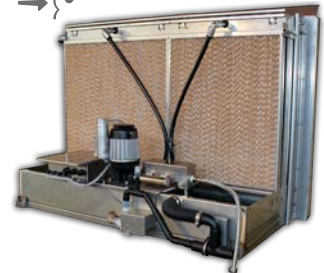

Evaporative

- Free cooling up to 22°F (12°C)
- Custom design to fit your application
- Hygienic operation with silver ion dosing system

SKD 🌫️

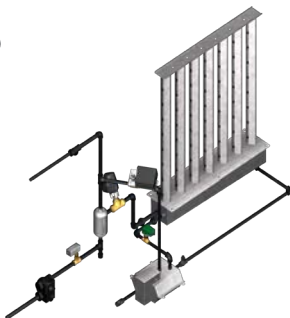

Direct Steam

- Capacities from 5 - 1650 lb/hr
- Jacketed or Multi-Steam™ SD/HD
- Unique electronic steam controller
- Optional pressurized condensate return (PCR) system

Distribution



Steam Distribution

- Multi-Steam™ SD/HD distribution
- S.A.M. & S.A.M.E2 wands
- SDU (Space distribution unit)

Controls



Humidity Controls

- Humidity controls/sensors
- Safety controls
- BACnet compatible

RESISTIVE ELECTRIC STEAM HUMIDIFIER

The resistive heating elements of the SKE4 convert electrical energy to heat energy that is then transmitted to the surrounding water, raising the temperature to its boiling point, creating steam. The process allows mineral-free, odorless, sterile steam to be generated quickly with any water condition.



SKE4 Advantages

- Capacities from 6-300 lb/hr (2.7-136 kg/hr)
- Separate plumbing, controls, and high-voltage sections
- Remove the stainless steel evaporation chamber with ease
- Patent-pending water level detection system using 2 sensor technologies
- Drain water tempered to below 140°F (60°C)
- Patented Anti-Foaming Energy Conservation (AFEC) System
- Available with BACnet MS/TP or Modbus communication interface
- Optional ethernet module for BACnet IP or Modbus IP, and Web services
- Independent scheduling system for unit operation and drain cycle

System Overview

Patent-Pending Water Level Detection System

- Self-cleaning and self-calibrating sensors
- Utilizes 2 different sensor technologies
- Precise and reliable water level detection
- Anti-Foaming Energy Conservation (AFEC) System: drains water when foam is detected

*All Silicone Piping

- No copper piping
- Resistant to higher water temperatures
- Suitable for all water types including DI and RO (Consult factory for Ultrapure water)

* Alternate piping available



Manual Drain

- Functions even without power

Power drain pump

Quick Connect Water Inlet

- No tools required

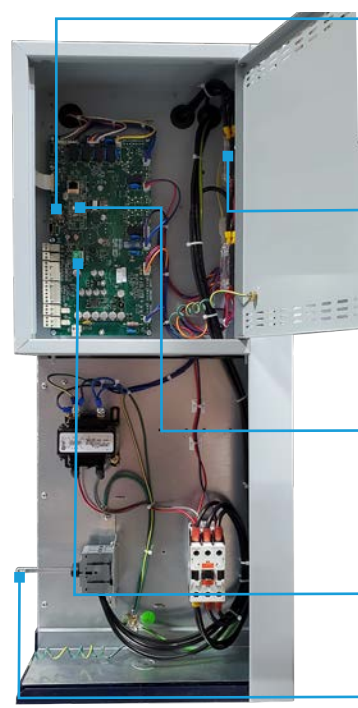

SD Card

- Event history log
- Firmware upgrade

SSR with External Heat Sink

- No cooling fan required
- Reduces noise level

Ethernet Module (optional)

- BACnet IP or Modbus IP
- Local and remote web services

BACnet MS/TP and Modbus Module (optional)

Disconnect switch

Specifications

Fast and Easy Maintenance



No tools required



No heavy lifting required

Advanced controller with multiple connectivity options
(see page 7)

Heating elements remain fixed within the enclosure

- No need to disconnect power cables
- No added weight from the elements when removing the evaporation chamber

Drop-down design limits lifting and simplifies handling

Evaporation chamber rests securely for easy maintenance



In-Duct Distribution

For Multi-Steam™ SD/HD and SAM in-duct distribution systems, refer to page 17.



SDU (Space Distribution Unit)

- Quiet operation
- No condensation
- Local or remote in-room steam distribution
- 3 models available (SDU4-1, SDU4-2, and SDU4-3)



For Models SKE4-N02 to SKE4-N30

Outdoor unit

- Fully insulated and constructed from heavy-duty steel
- Stainless steel bottom drip pan
- Zinc primer and polyurethane powder coating for resistance against scratches and corrosion on the exterior and interior surfaces
- Built-in anti-freeze and overheat protection
- Easy installation on a roof curb, stand or slab
- Connection can be made from side or bottom of unit for flexibility in any configuration



Output and Consumption

Model	Steam		Consumption								Steam Output		
	Capacity lb/hr [kg/hr]	Power (kW)	Amperage								Qty	Diameter inches [mm]	Space Distribution Unit (SDU)
			120/1	240/1	208/1	208/3	480/1	480/3	600/1	600/3			
SKE4-N02	6 [2.7]	2	17	8.5	10	-	4.5	-	3.5	-	1	1 3/8 [35]	SDU4-1
SKE4-N04	12 [5.5]	4	-	17	19	11.5	8.5	5	7	4	1	1 3/8 [35]	SDU4-1
SKE4-N06	18 [8]	6	-	26	30	16.5	13	7.2	10.5	6	1	1 3/8 [35]	SDU4-1
SKE4-N10	30 [14]	10	-	-	-	28	-	12	-	10	1	1 3/8 [35]	SDU4-2
SKE4-N14	40 [19]	13.5	-	-	-	38	-	16.5	-	13.5	1	1 3/8 [35]	SDU4-2
SKE4-N16	48 [21.8]	16	-	-	-	45	-	-	-	16	1	2 [51]	SDU4-3
SKE4-N20	60 [28]	20	-	-	-	-	-	25	-	20	1	2 [51]	SDU4-3
SKE4-N30	90 [41]	30	-	-	-	-	-	36	-	30	1	2 [51]	SDU4-3
SKE4-N20 L	60 [28]	20	-	-	-	56	-	-	-	-	1	3 [76]	-
SKE4-N40	120 [56]	40	-	-	-	-	-	50	-	40	1	3 [76]	-
SKE4-N50	150 [68]	50	-	-	-	-	-	60	-	50	1	3 [76]	-
SKE4-N60	180 [82]	60	-	-	-	-	-	72	-	60	1	3 [76]	-
SKE4-N30X	90 [41]	30	-	-	-	83.4	-	-	-	-	1	3 [76]	-
SKE4-N40X	120 [56]	40	-	-	-	111	-	-	-	-	1	3 [76]	-
SKE4-N70	210 [95]	70	-	-	-	-	-	84	-	70	1	3 [76]	-
SKE4-N80	240 [108]	80	-	-	-	-	-	96	-	81	2	3 [76]	-
SKE4-N90	270 [122]	90	-	-	-	-	-	109	-	91	2	3 [76]	-
SKE4-N100	300 [136]	100	-	-	-	-	-	120	-	96	2	3 [76]	-

Note: Designate the letter M for modulating units (i.e.: SKE4-N20M)



SKE4-N02
SKE4-N04
SKE4-N06

SKE4-N10 SKE4-N20
SKE4-N14 SKE4-N30
SKE4-N16

SKE4-N20L SKE4-N50
SKE4-N40 SKE4-N60

SKE4-N30X SKE4-N80
SKE4-N40X SKE4-N90
SKE4-N70 SKE4-N100

Integrated, Multi-Platform Controller

The SK Controller is configured specifically for your SKE4, SKG4 or SKS4 Humidifier.

- User-friendly interface consisting of a menu driven 128 x 64 LCD with 8 function buttons for faster configuration and operation
- User rights management allows for menu to display only functions available to the category of user logged in
- Quick Config menu allows for faster and easier installation, by displaying only the most commonly used functions and configurations
- Independent scheduling system for unit operation and drain cycle, configurable via the menu or the BACnet communication interface
- In-field firmware upgradeable via SD card, USB or BACnet
- Simple viewing and exporting of trending log and alarm log

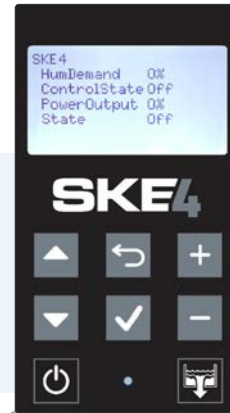

One controller, one menu across humidifier types provides consistency and ease of use.



Optional Features:

- The selectable BACnet MS/TP or Modbus communication interface allows access to over 75 objects/registers for integration with a BMS and IoT (Internet of Things)
- Ethernet Module
 - o BACnet IP or Modbus IP
 - o Web services make it possible to perform humidifier configurations, remote diagnostics and many more functions from any location



RESIDENTIAL HUMIDIFIER

Humidifying your home with a Nepronic SKR residential steam humidifier protects you from winter ailments. It reduces dry skin, sinus problems and scratchy throats by creating a healthier, more comfortable living environment. Proper humidity levels also protect valuables from permanent damage.



SKR Advantages

- Steam capacity from 4.5 to 12 lbs/hr (2 to 5.4 kg/hr)
- Permanent cleanable stainless steel evaporation chamber
- Patented siphon drain requires no drain valve or external tap
- Environment friendly – no plastic cylinders to replace
- On/Off operation, modulation optional
- Drain water tempered to below 140°F (60°C)
- Self-cleaning heating elements

System Overview

Intelligent Controller

- Manages control sequences and performs self diagnostics
- On/Off or modulating control functions
- LED status display

Evaporation Chamber

Permanent, easily serviceable, stainless steel chamber. No need to replace expensive plastic bottles.

Heating Element

Self-cleaning, electric heater elements.

Internal Plumbing Assembly

High Voltage Quick Connect

Safe, fast and easy connection and reconnection of line voltage.

Water Level Sensors

Conductive water level sensors for normal operation level and drain level.

Patented Siphon Drain

Eliminates the use of a physical device such as a drain valve or external P trap to drain water.

Water Fill Valve



Specifications

Output and Consumption

Model	Capacity	Power (kW)	Amperage			Width	Height	Depth	Height with SDU
			120V	208V	240V				
SKR14	4.5 lb/hr 2.0 kg/hr	1.4	12A	-	-	10.5" 267mm	14.5" 368mm	9" 229mm	19.75" 500mm
SKR25	7.5 lb/hr 3.4 kg/hr	2.5	-	12A	11A	10.5" 267mm	14.5" 368mm	9" 229mm	19.75" 500mm
SKR30	9 lb/hr 4.1 kg/hr	3	-	14.5A	13A	10.5" 267mm	14.5" 368mm	9" 229mm	19.75" 500mm
SKR40	12 lb/hr 5.4 kg/hr	4	-	19.2A	17A	10.5" 267mm	14.5" 368mm	9" 229mm	19.75" 500mm

Note: Operation with maximum 0.5" (125Pa) duct static pressure at steam distribution manifold location.

In-duct distribution

For a duct distribution installation, the SKR requires a SAM Steam Distribution System (see page 17).



Integrated SDU (Space Distribution Unit)

This option is typically used in small stores, small warehouses and laboratories where the visibility of the unit is not an issue.



Remote SDU (Space Distribution Unit)

Ideal for condos/apartments without a duct network, the remote SDU is designed for through-the-wall installation to provide humidification directly into the room.

Features

- Distribution unit is installed through a wall partition
- SKR humidifier is installed in a closet or other closed location
- Modern design of SDU front grill blends into any decor
- Low noise (less than 40dBa at 1m)
- Standard, 120Vac power supply



SKG4 gas fired



GAS FIRED HUMIDIFIER

The SKG4 gas fired humidifier generates mineral free, odorless, sterile steam by using the power of natural gas or propane. Cost of operation and its carbon footprint is much lower than electric humidifiers with equivalent control accuracy.

SKG4 Advantages

- Steam capacity from 110 to 810 lbs/hr (50 to 370 kg/hr)
- Turn down ratio of 10:1 (minimum) up to 40:1 (maximum)
- Functions with Tap, RO or DI water
- Combustion efficiency: 83% to 87%
- For Multi-Steam and SAM in-duct distribution systems, refer to page 17
- Easy servicing: clean and re-install within minutes
- Smallest footprint in the industry
- Patented Anti-Foaming Energy Conservation (AFEC) System
- Advanced controller with multiple connectivity options (see page 7)
- Waste water drained below 140°F (60°C)
- Self-adjusting burner for altitude compensation



System Overview

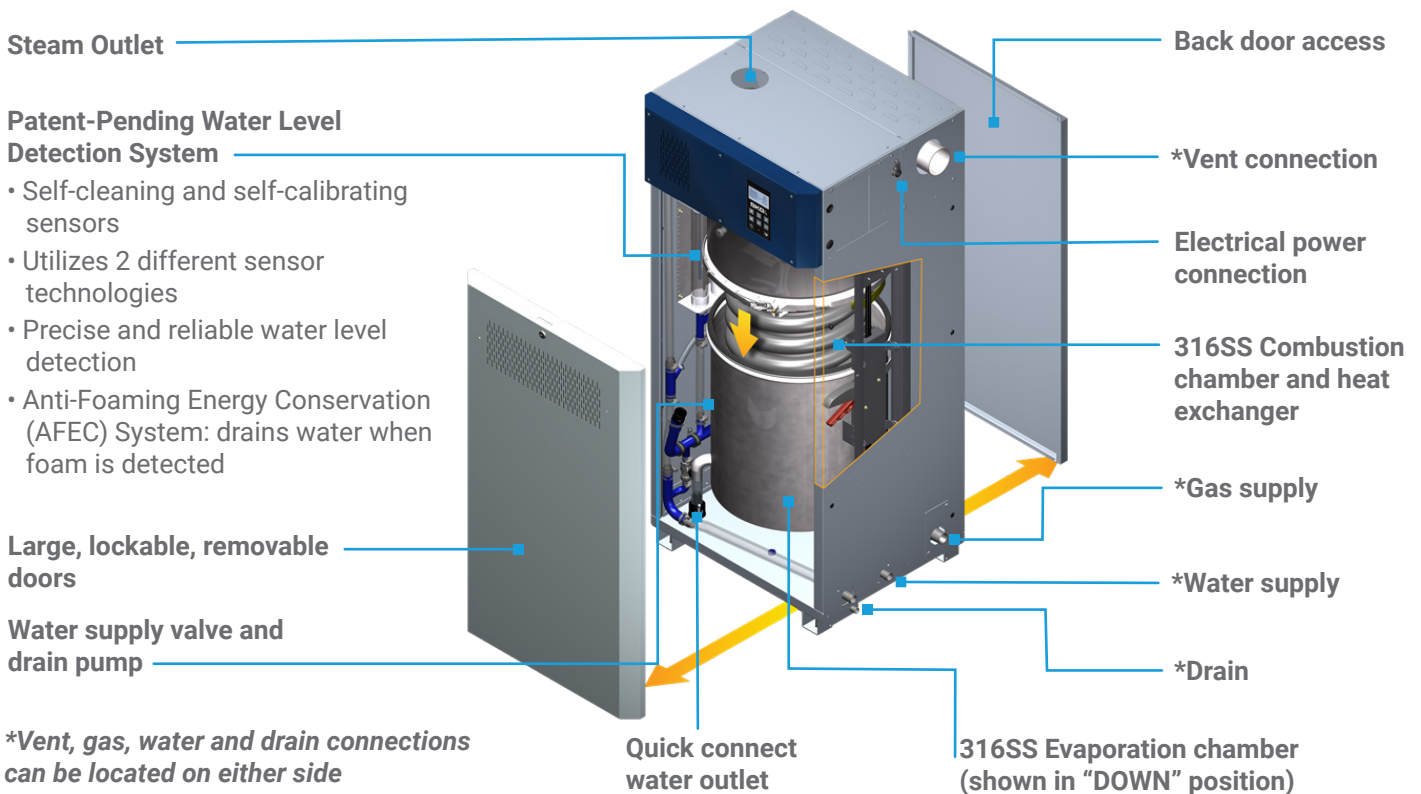

Specifications

Output and Consumption

Model	No. of Modules	Steam Capacity (lb/hr) [kg/hr]	Input Capacity (btu/hr)[kW]	Current at 120Vac (A)	Current at 208Vac (A)	Current at 240Vac (A)	No. of Outlets	Multi-Steam header diam. in [mm]
SKG4-N1101 N/P	1	110 [50]	165,000 [49]	6.0	3.5	3.0	1	3" [76]
SKG4-N1551 N/P	1	155 [70]	215,000 [63]	6.0	3.5	3.0	1	3" [76]
SKG4-N1801 N/P	1	180 [80]	240,000 [70]	6.0	3.5	3.0	1	3" [76]
SKG4-N2101 N/P	1	210 [95]	249,000 [73]	6.0	3.5	3.0	1	3" [76]
SKG4-N2652 N/P	2	265 [120]	380,000 [112]	9.0	5.2	4.5	2	4" [100]
SKG4-N3102 N/P	2	310 [140]	430,000 [126]	9.0	5.2	4.5	2	4" [100]
SKG4-N3502 N/P	2	350 [160]	464,000 [136]	9.0	5.2	4.5	2	4" [100]
SKG4-N4052 N/P	2	405 [185]	498,000 [146]	9.0	5.2	4.5	2	4" [100]
SKG4-N5053 N/P	3	505 [230]	704,000 [206]	12.0	7.0	6.0	3	5" [125]
SKG4-N5603 N/P	3	560 [255]	713,000 [209]	12.0	7.0	6.0	3	5" [125]
SKG4-N6103 N/P	3	610 [275]	747,000 [219]	12.0	7.0	6.0	3	5" [125]
SKG4-N7104 N/P	4	710 [320]	953,000 [279]	15.0	8.7	7.5	4	(2x) 4" [100]
SKG4-N7654 N/P	4	765 [345]	962,000 [282]	15.0	8.7	7.5	4	(2x) 4" [100]
SKG4-N8104 N/P	4	810 [370]	996,000 [292]	15.0	8.7	7.5	4	(2x) 4" [100]

Outdoor Unit

- Hinged doors provide full access (serviceability) from the front, back and top of unit
- Fully insulated and constructed from heavy duty steel
- Stainless steel bottom drip pan
- Zinc primer and polyurethane powder coating for resistance against scratches and corrosion
- Built-in anti-freeze and overheat protection
- Easy installation on a roof curb, stand or slab
- Connection can be made from side or through the roof curb



Modular Design

Flexible Solution for Indoor/Outdoor Applications

Modular design offers flexibility and convenience; each module adds up to 210 lbs/hr (100 kg/hr) of steam capacity. With the smallest footprint in the industry, the SKG4 module can be easily installed and assembled on site when access is limited. Module assembly can be arranged in line, in an L shape, or back to back to accommodate any specific space conditions. Feed water, gas, water drain and flue connections can be located on either side of the enclosure.



SKS4 steam to steam



STEAM TO STEAM HUMIDIFIER

The SKS4 humidifier provides chemical free steam by using an on-site central boiler or steam generating station as a heat source. The raw steam under pressure from the boiler provides the energy to produce clean steam through a heat exchanger.

SKS4 Advantages

- Capacities from 17 to 1250 lbs/hr (8 to 570 kg/hr) of steam
- Stainless steel (for raw steam) heat exchangers
- Comprehensive scale management system
- Ease of servicing: clean and re-install within minutes
- Patent-pending water level detection system using 2 sensor technologies
- Uses either domestic, RO or DI water
- For Multi-Steam and SAM in-duct distribution systems, refer to page 17
- Available with BACnet MS/TP or Modbus communication
- Optional ethernet module for BACnet IP or Modbus IP, and web services
- Patented Anti-Foaming Energy Conservation (AFEC) System
- Drain water tempered to below 140°F (60°C)



System Overview

Heat Exchanger

Raw steam passes through the heat exchanger, thus providing the energy to produce clean steam. Made with 316 stainless steel for 5 - 15 psig steam.

Evaporation Chamber

The 304 stainless steel evaporation chamber is equipped with handles for easy removal without any tools.

Steam Outlet

Insulated Cabinet

The fully enclosed steel, powder-painted cabinet with 1" (25mm) thick insulation eliminates accidental contact with hot surfaces and saves energy.

Scale Trap Trays

These trays can be accessed from the top of the unit, allowing for easy maintenance and scale removal.

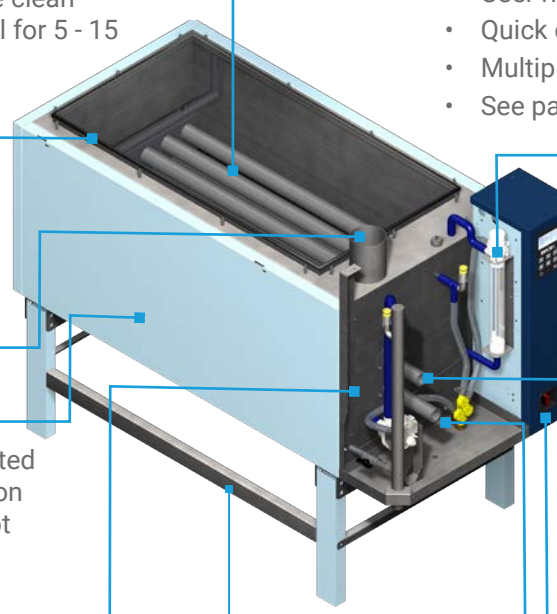

Floor Stand

Adjustable legs ensure proper level when installed directly on the floor.

Built-in Controller

- Intuitive menu-driven user interface
- User rights management
- Quick config menu
- Multiple connectivity options
- See page 7 for more details



Patent-Pending Water Level Detection System

- Self-cleaning and self-calibrating sensors
- Utilizes 2 different sensor technologies
- Precise and reliable water level detection
- Anti-Foaming Energy Conservation (AFEC) System: drains water when foam is detected

Pressurized Steam Supply

Disconnect Switch

Condensate Return

Outdoor unit available

Specifications

Heat Exchanger - SLP Stainless Steel 316 (For Raw Steam)



Model	Output Steam Capacity lbs/hr [kg/hr] for Supply Steam Pressure					Steam Outlet Qty & Ø in [mm]
	5 PSI [34.5 kPa]	8 PSI [55.1 kPa]	10 PSI [68.9 kPa]	12 PSI [82.7 kPa]	15 PSI [103 kPa]	
SKS4-050-SLP	17 [8]	27 [12]	33 [15]	40 [18]	50 [23]	(1x) 2" [51]
SKS4-100-SLP	33 [15]	53 [24]	67 [30]	80 [36]	100 [45]	(1x) 3" [76]
SKS4-130-SLP	43 [19]	69 [31]	87 [39]	104 [47]	130 [59]	(1x) 3" [76]
SKS4-190-SLP	63 [28]	101 [46]	127 [57]	152 [69]	190 [86]	(1x) 3" [76]
SKS4-290-SLP	97 [44]	155 [70]	193 [87]	232 [105]	290 [132]	(1x) 4" [100]
SKS4-390-SLP	130 [59]	208 [94]	260 [118]	312 [142]	390 [177]	(1x) 4" [100]
SKS4-500-SLP	167 [76]	267 [121]	333 [151]	400 [182]	500 [230]	(1x) 5" [125]
SKS4-690-SLP	230 [104]	368 [167]	460 [209]	552 [251]	690 [314]	(1x) 5" [125]
SKS4-950-SLP	317 [144]	507 [230]	633 [287]	760 [345]	950 [432]	(2x) 4" [100]
SKS4-1250-SLP	417 [189]	667 [303]	833 [378]	1000 [454]	1250 [568]	(2x) 5" [125]

Self-Cleaning System

Scale Management System

The SKS4 is designed with a comprehensive scale management system. The supply of cold water, located at the sloped bottom of the evaporation chamber, forces the precipitated mineral deposits into baskets that can easily be removed.



Modulating Control

The SKS4 is supplied with a Neptronic linear actuated globe valve, giving full modulation control of low pressure steam. The globe valve is available with either brass or stainless steel trim as an option.



DIRECT STEAM INJECTION HUMIDIFIER

The SKD direct steam injection system uses low pressure steam from an in-house boiler (maximum pressure 1 bar/15PSI) to humidify the air.

SKD Advantages

- Custom designed to meet your specific steam capacity and non-wetting distance requirements
- 5 steam distribution configurations: Multi-Steam™ SD, Multi-Steam™ HD, or Jacketed (Single Tube, Multi-Tube, or Mini Rack)
- Unique Electronic Steam Controller (ESC) manages the sequence of operation to optimize energy efficiency and prevent condensate ejection
- Optional patent-pending pressurized condensate return (PCR) system. No gravity drain - no maintenance - returns condensate to steam source

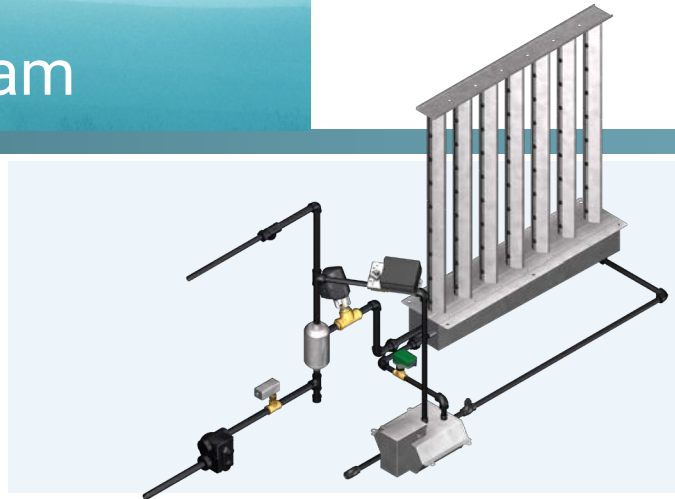

System Overview

Steam Separator

Supplies condensate-free steam to the steam control valve, while discharging condensate to the steam trap.

Steam Control Valve

Provides full modulation of the low pressure steam flow for a better control of the humidity level.

Temperature Sensor

Monitors steam temperature and detects abnormal condensate level to ensure safe operation.

Steam Distribution System

- Multi-Steam Configuration**
- Multi-Steam™ SD
 - Multi-Steam™ HD

Jacketed Tube Configuration

- Single Tube
- Multi Tube
- Mini Rack

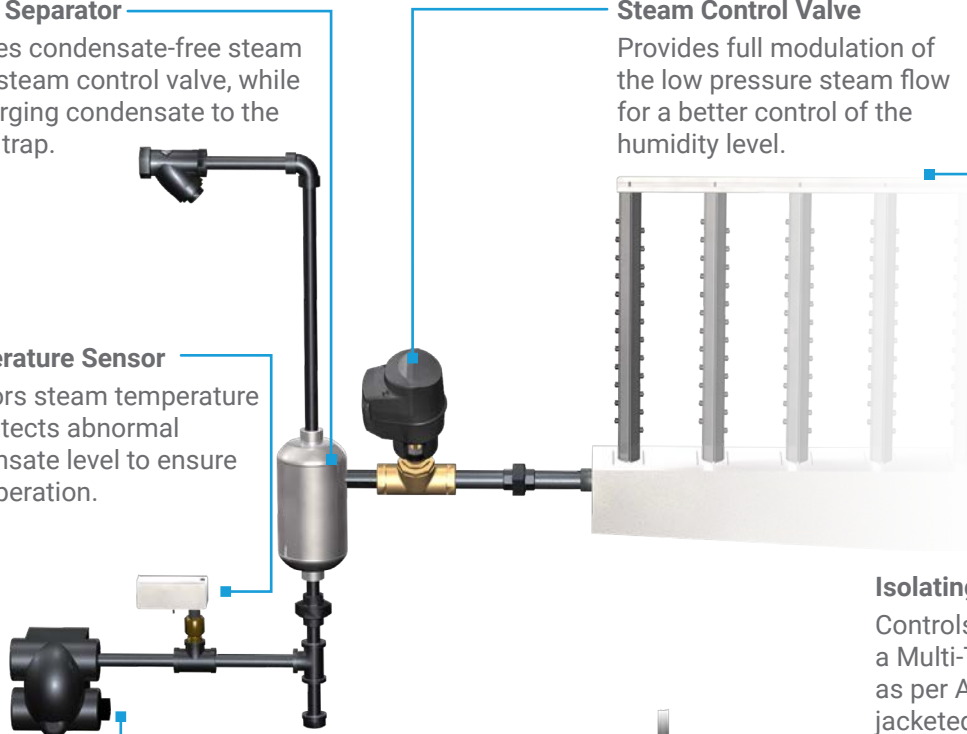

Isolating Valve

Controls steam supply to the jacket in a Multi-Tube configuration (mandatory as per ASHRAE standard 90.1 for all jacketed tube configurations).

F&T Steam Trap

Eliminates condensate from the steam line.

PCR

Optional patent-pending pressurized condensate return (PCR) system.

- No gravity drain
- No maintenance
- Returns condensate to steam source

Specifications

PCR

Pressurized Condensate Return system

The Neptronic Pressurized Condensate Return system (PCR) returns condensate generated within the steam dispersion tubes of a direct steam humidifier back to the steam source, thus eliminating the need for a gravity drain. Presently, the only other available technology is a pressurized steam humidifier with a heat exchanger (or re-evaporator).

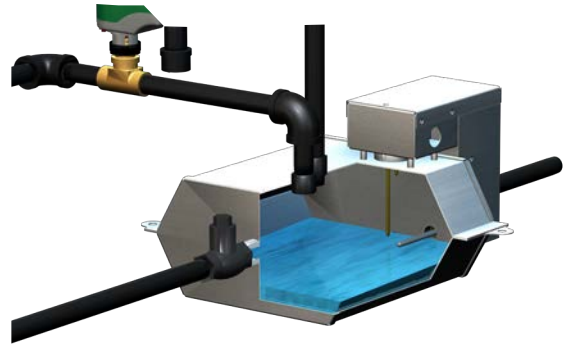

Description	Neptronic PCR System (Pressurized Condensate Return)	Competitors Re-evaporators (Internal Heat Exchanger)
Real-time monitoring	Yes	No
BMS Integration	BACnet or Modbus	No
Maintenance	Not required	Systematic verification is a must*
Cleaning	Not required	De-scaling*
Downtime	None	During maintenance or when equipment is offline due to fouling*
Flooding of header	None	Possible due to reduced capacity due to fouling and standard piping configuration
Accessibility	Outside the duct for easy access	Standard cleaning procedure requires access to the top of header often located in duct (may require duct access by door)*
Compatibility	Insulated and non-insulated steam distributors and headers	Only insulated steam distributors and headers
Installation	Lowest clearance with simple and flexible installation due to smaller components	Higher clearance and integral design forces components below duct, resulting in potential ceiling clearance issues

*See manufacturer's manual for more information

ESC Controller

Unique in the Industry

- Centralized wiring of sensors, valves and humidity controls
- Easy start-up and diagnostics
- Factory pre-configured operating temperature range
- 24 Vac operation
- BACnet or Modbus compatible



Multi-Steam™ SD (Non-insulated)

- Lowest capital cost injection system
- Easiest installation... contractor's favorite
- Header with built-in slope for improved condensate elimination

Multi-Steam™ HD (Insulated)

- Same as Multi-Steam™ SD plus: X-Stream™ Technology (see page 17)
- Lowest heat transferred to the airstream
- Lowest condensate produced

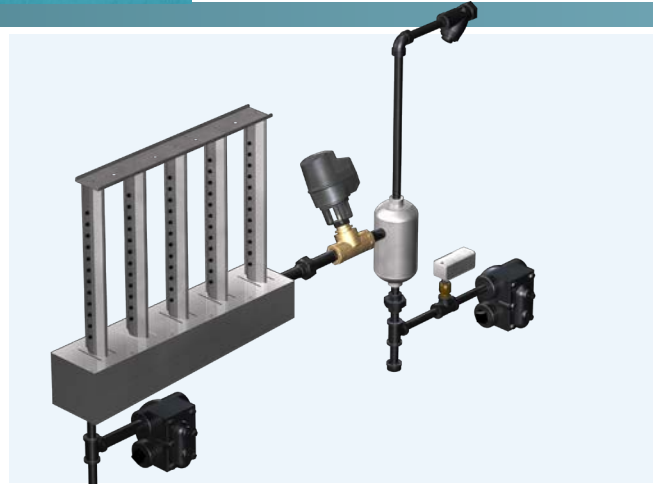

JACKETED

Single Tube

- For duct installations
- Low capacity applications: 5 - 170 lb/h (2 - 77 kg/h)
- Average non-wetting distance

Multi-Tube

- For duct or AHU installations
- Medium to high capacity applications: 5 - 1650 lb/h (2 - 750 kg/h)
- Short non-wetting distances
- Optional pressurized condensate return (PCR) system

Mini Rack

Same as Multi-Tube, plus:

- Designed for limited space installations such as reduced duct height
- Tubes pre-assembled on header

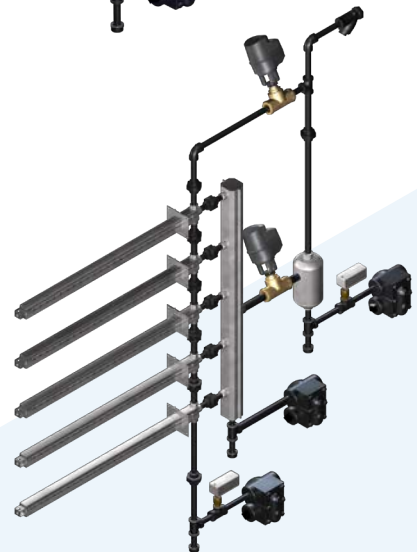

S.A.M.

- Short absorption distance (less than 5ft/1500mm)
- Stainless steel tube with brass nozzles
- Nozzles prevent condensate from collecting in the duct
- Inclined steam dispersion tube to return condensate back to humidifier or steam trap

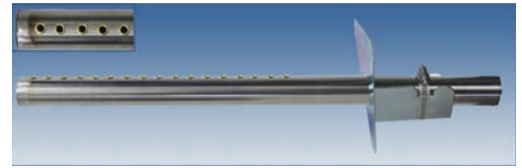

S.A.M.

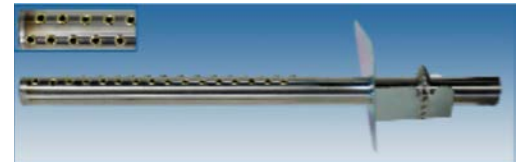

S.A.M.E2

Multi-Steam™ SD (Non-Insulated)/HD (Insulated)

- For absorption distances of less than 3ft (900mm)
- Custom built for the duct or AHU
- Header with built-in slope for improved condensate elimination
- Brass insertion nozzles (SD), or 304 stainless steel eyelets (HD)
- Completely assembled (HD) or welded (SD) at the factory, or collapsible for in-field assembly

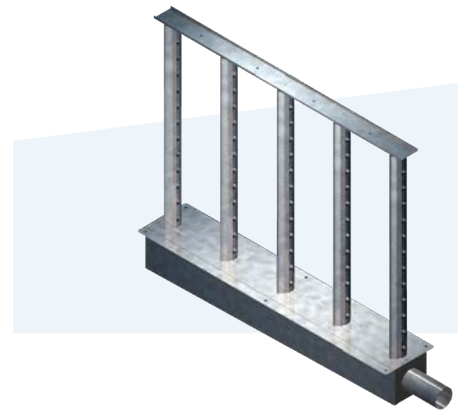

X-Stream™ Technology (HD Insulated)

- High efficiency insulated steam distributor (channel and header) with steam ejector eyelets
- Double wall 304 stainless steel with encapsulated Armacell
- UT/Solaflex™ foam insulation
- Specially engineered 304 stainless steel eyelets prevent condensate ejection on start up and any modulating humidity demand

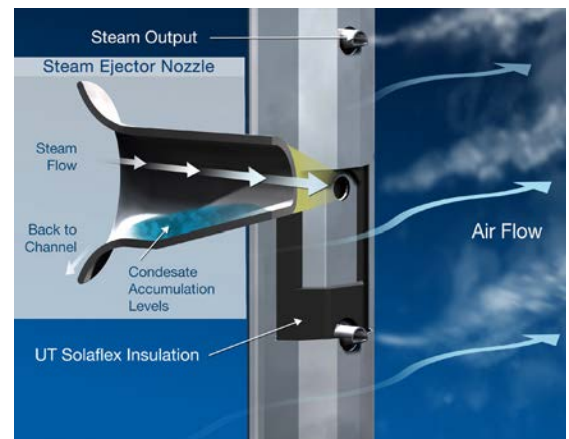

Steam Distribution Applications

Steam Distribution System	SKR ⚡	SKE4 ⚡	SKG4 🔥	SKS4 ↑↑↑	SKD ???
Multi-Steam™ SD		•	•	•	•
Multi-Steam™ HD		•	•	•	•
S.A.M.	•	•			
S.A.M.E2	•	•	•	•	



EVAPORATIVE HUMIDIFIER

With the SKV evaporative humidifier, water is supplied to the top of the evaporative module and flows down the wet media. Warm dry air passes through the wet media evaporating the water, thereby raising the humidity level.

SKV Advantages

- Very low machine energy consumption (<1kW)
- Hygienic operation
- Environmentally friendly
- Very low maintenance
- Free cooling up to 21.5°F (12°C)
- Custom modular design to fit any application
- Low pressure drop
- Fully ETL approved



System Overview

Inorganic Fibreglass Media

Hygienic, fire resistant and incombustible corrugated media, provides exceptional moisture absorption for continuous humidification and evaporative cooling, even at high air velocity.

Parametric Design

Use the Neptronic Humidisoft web application to customize the evaporative module to your exact duct dimensions. This minimizes the need for blanking plates, thus ensuring a lower pressure drop.

Circulation Pump

Robust pump functions with tap or RO water

Water Distribution Drawer

Easy to remove for cleaning and maintenance.

Drain Pump

Fast and reliable pump that lifts and re-circulates the drained water.

Staging Valves

Offers up to 5 stages providing very flexible and accurate control.

Silver Ion Cartridge

Water pre-treated with 5µm pre-filter and anti-bacterial silver ions prevent microbial growth.

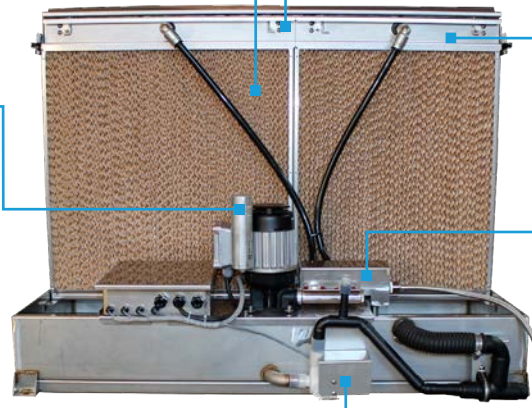

SKV Controller

- Master/slave configuration for up to 4 evaporative modules
- On/Off or modulating control type
- Real-time clock with flexible scheduler
- Simple viewing and exporting of trending log and alarm log
- In-field firmware upgradeable via SD card
- Easy connection with only one 6-wire control cable
- Stainless steel IP56 rated (equivalent to NEMA type 4) enclosure for outdoor installations



Specifications

Nomenclature SKV R 95 C 1 D C

Type							
R: Recirculation							
D: Direct Feed							
O: OEM							
Evaporation Factor							
65: 65%							
75: 75%							
85: 85%							
95: 95%							
Controller							
C: Controller (standard)							
B: BACnet controller							
-: None							
No. of Stages							
1: 1 Stage							
2: 2 Stages							
3: 3 Stages							
4: 4 Stages							
5: 5 Stages							
Droplet							
D: Droplet separator included (when required)							
Voltage							
A: 120Vac							
C: 230Vac							

Standards for media

North American:

- UL 900, Air Filter Units, [Class I (no flame or spark, less than 2.5 sq.in of smoke)]

European:

- EN 13501-1, Fire classification of construction products and building elements - **Part 1: Classification using data from reaction to fire tests**
 - EN 1182, Non combustibility test method of building materials
 - EN 13823, Reaction to fire test for building products. Fire class: **A2**; Smoke production class: **s2**; flaming particles class: **d0**
- ISO 846, Evaluation of the action of microorganisms' microbiology testing lab
- ILH Berlin tested and found to fulfill the requirements from VDI6022 Part 1, suitable for use in HVAC systems

Hygienic and Safe

SKV Media Panels

- Inorganic and inflammable material
- Trouble free maintenance
- No water treatment required
- No risk of over saturation
- Media frame made of stainless steel
- Media easily removable from stainless steel frame

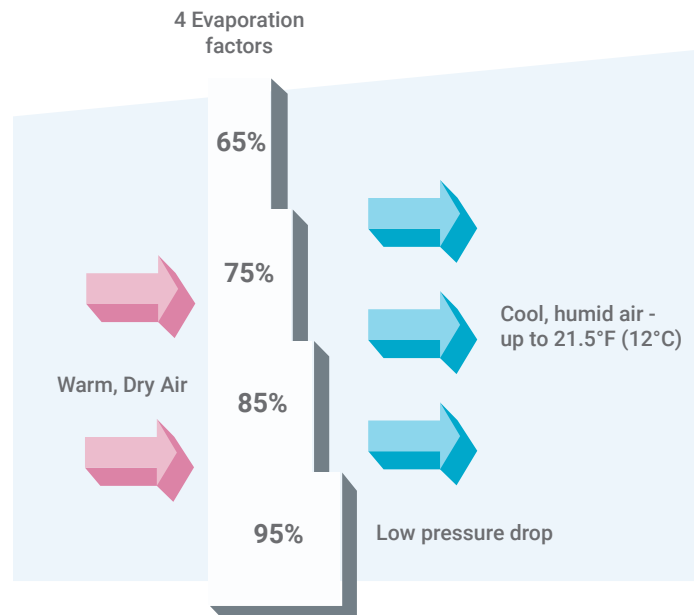

SKH high pressure atomizer

ATOMIZING HUMIDIFIER

The SKH pumps water at high pressure through a series of nozzles to produce a fine mist. By way of the adiabatic process, the SKH uses energy (heat) from the surrounding air to evaporate the fine mist (water droplets). This evaporative cooling/humidification process provides a very low energy impact with power consumption values of 2 HP to 10 HP (1.5 kW to 7.5 kW), which is less than other technologies of equivalent capacity, such as compressed air.



SKH Advantages

- Up to 21.5°F (12°C) of free cooling
- Close control humidity
- Uses energy from ambient air
- Fast and easy maintenance
- Up to 3 zones
- View and control from any zone
- Each SKH unit has an integrated system controller that manages all sequences of operation for each zone
- Unique to Neptronic, you can tap into the system directly from within the zone by connection to the zone's thermostat/humidistat
- With its BACnet MS/TP communication, integrate the system with your Building Management System (BMS)

System Overview



Nozzles

Anti-drip nozzles produce droplets of less than 20µm.

Variable Frequency Drive

Regulates motor and pump RPMs to ensure greater energy savings and longer pump life.

Intelligent Controller

Networkable (BACnet MS/TP), field configurable controller manages sequences of operation and provides close control for up to 4 stages and 3 zones.

Pressure Regulator and Gauge

Water inlet pressure regulator and gauge to adjust the appropriate water inlet pressure.

Pre-filter and Silver Ion Cartridge (included with SKH100 and SKH200 models)

Water pre-treated with 5µm pre-filter and anti-bacterial silver ions prevent microbial growth.

High Pressure Water Pump

High efficiency, water cooled axial piston pump (maintenance free).

High Pressure Water Outlet

Ranges varying from 66 - 4638 lb/h (30 - 2108 kg/h) per pump station depending on model.

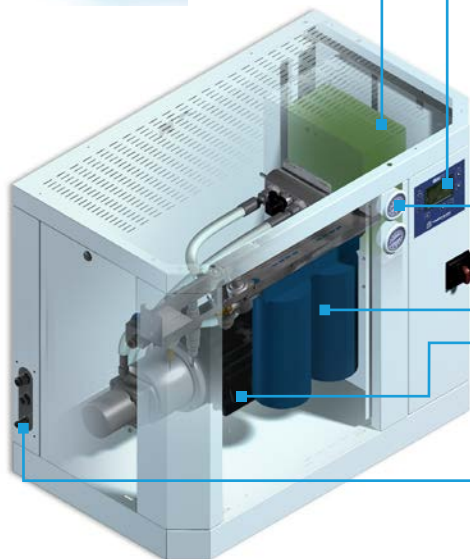

Specifications

Models and Capacities

Model	Capacity		Motor	
	lb/hr	kg/hr	HP	kW
SKH100	66-660	30-300	2	1.5
SKH200	141-1126	64-512	3	2.25
SKH300	231-1454	105-661	5	3.75
SKH600	453-2343	206-1065	7.5	5.6
SKH900	585-3645	266-1657	10	7.5
SKH1200	805-4638	366-2108	10	7.5

Typical Distribution



Custom nozzle racks make it ideal for use in AHUs.

- 1 to 4 stages for sequential control
- 1st stage modulates for close control
- Droplet separator if required



Spray directly into the space for high ceiling applications (approximately 30ft/9m)

- Flexible nylon high-pressure hoses or hydraulic high-pressure hoses
- With stainless steel, quick connect fittings



Spray directly into the space with a fan (MDU: Mist Distribution Unit) for low ceiling applications (minimum 15ft/4.6m)

- Horizontal air flow assists in the evaporation process



Specify your Humidifier online

Humidifier System Design and Specification Web Application

Ready to specify your Humidifier? Neptronic has developed a web application that saves you time when sizing and specifying Neptronic commercial, industrial or residential humidifiers.



Features

- Automatic humidification load calculation
- Web based
- Selection specific report generator
- Only options related to your selections appear
- Manage users, clients, job sites and humidifier specs
- History log



Project	Humidifier	Dispersion	Options	Reports	Pricing
Type					
<input checked="" type="radio"/> Isothermal (Hot Steam) <input type="radio"/> Adiabatic (cold mist)					
Category					
<input type="radio"/> Commercial Electric SK300 <input type="radio"/> Commercial Gas <input type="radio"/> Residential Electric <input checked="" type="radio"/> Commercial Electric SKE4 <input type="radio"/> Steam to Steam <input type="radio"/> Direct Steam					
Entering Air Conditions		Indoor Conditions		Distribution	
Temperature <input type="text" value="60"/> °F		Temperature <input type="text" value="70.0"/> °F		<input checked="" type="radio"/> In Duct	
Relative Humidity <input type="text" value="35"/> %		Relative Humidity <input type="text" value="40"/> %		<input type="radio"/> In Space	
Ventilation System					
<input type="radio"/> Natural <input checked="" type="radio"/> Mechanical <input type="radio"/> Economizer					
Total Air Flow <input type="text" value="3333"/> CFM				Outside Air <input type="text" value="100"/> %	
Humidifier(s)					
<input checked="" type="checkbox"/> Enter Load Manually		Entered Load <input type="text" value="4.50"/> lb/hr		Total Capacity <input type="text" value="6.00"/> lb/hr Select Model	

Easy to Use

Go to neptronic.com, select Humidisoft and log in. Enter design requirements and Humidisoft automatically calculates the humidification load and adjusts available options based on your selections. When done, print a complete schedule, CSI and/or submittal report at the click of a button.

Project	Humidifier	Dispersion	Options	Reports	Pricing
Voltage					
<input type="text" value=""/> <input checked="" type="checkbox"/> Show Voltages for current model only					
Control					
<input type="radio"/> On / Off <input checked="" type="radio"/> Modulating					
Humidistat Type					
<input checked="" type="radio"/> None <input type="radio"/> Wall Humidistat HRO20 <input type="radio"/> Wall Humidity Sensor HRL24 <input type="radio"/> Wall Humidity Sensor SHR10 <input type="radio"/> Duct Humidity Sensor (return duct) SHC80 <input type="radio"/> Wall Humidistat HRO20 + Wall Humidity Sensor SHR10 <input type="radio"/> Wall Humidistat HRO20 + Duct Humidity Sensor (return duct) SHC80 <input type="checkbox"/> Window Temperature Sensor SHWO-11 <input type="checkbox"/> Outdoor Temperature Sensor STO2-11					

Humidifier Controls and Sensors

**HRO20 / HROB20 (BACnet)
Humidity Controller**



- BACnet MS/TP (model HROB20 only)
- 4 analog and 2 dry contact outputs
- 2 external sensor inputs
- Alarm and low signal selector input
- Independently configure PID on humidify & dehumidify ramps
- Adjustable setpoint with auto reset from external sensor

**SHS20
Room High Limit Humidistat**



**HRC20
Room Humidistat**



- **SHS20** - High-limit setpoint dial (20-90 %RH)
- **HRC20** - Humidity setpoint dial (10-60 %RH)
- Built-in humidity sensor
- 24Vac or 24Vdc
- 1 dry contact output

**HRL24
Room Humidistat**



- Used to program the SK Humidifiers
- Icon-driven information and 1 line of text information
- 4 wires between humidistat and SK
- Programmable PID on humidity

**SHR10
Wall Mount Humidity Sensor**



- Built-in temperature sensor
- Plastic cover for wall mount installation
- 2 analog outputs (0 - 10 Vdc)
- High accuracy and stability

**SHC80
Duct Mount Humidity Sensor**



- Built-in temperature and humidity sensor
- 2 analog outputs (0 - 10 Vdc)
- Status LED

**SHS80
Duct Mount High Limit Humidistat**



- Built-in temperature and humidity sensor
- On/Off high limit humidistat with on-board setpoint adjustment (20-90 %RH)
- 2 analog outputs (0 - 10 Vdc)
- Status and high limit LEDs
- 1 dry contact output

Humidifiers for Every Application



Electric



Gas



Steam-to-Steam



Direct Steam



Evaporative



High Presssure



Software



neptronic.com